

## **Development of Wireless Monitoring System for Neonatal Intensive Care Unit**

**N.S. Joshi<sup>1</sup>, R.K. Kamat<sup>2</sup>, P.K. Gaikwad<sup>3</sup>**

### **Abstract**

*The research paper depicts a Development of a Wireless Monitoring System for Neonatal Intensive Care Unit (NICU); which is an isolated room for a premature/weak new-born baby. It provides the environmental condition as its mother's belly. Lack of attention to thermoregulation continues to be a cause of unnecessary deaths in the neonatal population. Maintaining a stable body temperature is essential to ensure optimal growth of premature and weak infants. As the temperature and humidity parameters play a vital role during the development of premature weak infants, this research work develops a wireless system which continuously monitors these parameters inside the NICU. The system deploys a set of suitable sensors for the system development. The analogue signals from sensors are processed using a Peripheral Interface Controller (PIC) microcontroller and further transmitted towards the receiving end with the help of Global System for Mobile Communications (GSM) modem using Application Terminal (AT) commands.*

### **Keywords**

*GSM Modem, NICU, PIC microcontroller, Sensors, Thermoregulation, Wireless Protocol*

### **1. Introduction**

The historical background of incubators is as given in [1]. In 1889, Doctor Alexander Lion created an incubator made of glass that was seeing through. He also adapted an automatic heating system for it, so that it didn't have to be constantly monitored and the babies could be cared for more easily. In 2011, Abbas Khudair Abbas [2], explained that a neonatal incubator is, usually, a small (approximately: 0.5 x 0.5 x 1 m<sup>3</sup>) cabinet with transparent walls to observe the infant easily.

**N.S. Joshi**, Department of Electronics, Willingdon College, Sangli, India.

**R.K. Kamat**, Department of Electronics, Shivaji University, Kolhapur, India.

**P.K. Gaikwad**, Department of Electronics, Shivaji University, Kolhapur, India.

An artificial climate is maintained inside the incubator, and which usually differs from the local environment with respect to temperature, humidity and/or oxygen concentration. The device may include an AC-powered heater, a fan to circulate the warmed air, a container for water to add humidity, a control valve through which Oxygen may be added, and access ports for nursing care. With the technology available currently, incubators use microprocessor-based control systems to create and maintain the ideal microclimate for the preterm neonate.

On the other hand, in case of radiant warmer, it is essential to maintain the temperature value, so that caloric expenditure and oxygen consumption would be minimal. It is mentioned in the article on radiant warmer given in [3], that newborn babies, in particular, the preterm and the low birth weight are exquisitely predisposed to hypothermia. No other equipment is identified more with the special care of newborn babies than the radiant warmers. Radiant warmers provide intense source of radiant heat energy. They also reduce the conductive heat losses by providing a warm microenvironment surrounding the baby. The radiant warmer (also called open care system) was developed as an 'open incubator' that ensures ready access to the baby.

In 2006, Yaseer Amer Al-Taweel [1] demonstrated that the survival rate of low birth weight infants cared for in incubators or under radiant warmers increases when warmer environment conditions are provided. This is particularly vital during the first week of life. Although providing a neutral thermal environment is essential for premature babies during the first month of life, primarily due to very high evaporative losses resulted by large skin surface area, this could only be achieved at a very small range of temperatures usually in a margin of +1 °C when the admission temperature to the incubator > 36 °C.

In 2009, Feng Dong-Qing Zang Yu and Liu Ya-lei [4], proposed the intelligent monitoring system for baby incubators based on Fuzzy-PID algorithm. The system was capable to continuously monitor the temperature and humidity inside incubator and give an alarm in time at local level only.

In 2011, Kranti Dive and R. W. Jasutkar [5], proposed an infant monitoring system by designing an embedded device, which was capable to monitor temperature and light intensity inside incubator. The proposed system was capable to monitor the parameters at local level only.

From the existing systems point of view, the Neonatal Intensive Care Units (NICUs) are facilitated with incubator along with the Radiant Warmer. In the report given by Stina Caxe [6], an Incubator is explained as a careful controller where the ambient temperature, humidity and skin temperature of baby can be maintained. It also helps to protect preterm infant from light, germs and noise that may cause infections, sickness or other types of diseases.

As per mentioned in the report given by Paediatric Oncall [7], a Radiant Warmer is a body warming device maintaining the body temperature of the baby and limits the metabolism rate. The heat loss in some new-born babies is rapid; hence body warmers provide an artificial support to keep the body temperature constant. In certain areas with very cold climate, babies are kept on Radiant Warmer for couple of hours; immediately after birth to ensure the baby is stabilized after birth. In 2011, D. C. Shah and U. D. Dalal [8], proposed a system acquiring data at desired sampling rate and monitoring fault with alarm indication.

The infants have to be kept in the Intensive Care Unit, when it is suffering from the problems as given in [9].

- If the delivery was very difficult, and requires the close observations.
- In case of premature/preterm infant (i.e. within 7), in which the baby has low birth weight (less than 1000- 2000 grams, or it is very small in size.
- If it is suffering from diseases like Jaundice, Dehydration, or Infections.
- If the baby is getting recovered from any critical surgery, or the mother is having a major disease such as diabetes.

In the context of aforesaid requirements and existing NICU systems, the present research work has developed an embedded system for NICU. It includes a wireless communication technology, as well as different sensors to obtain various physical parameters of incubator and radiant warmer. The system implemented here transmits the acquired

information (from sensors) towards the care taker unit at the receiving end with the help of established wireless protocols.

## 2. Overview of the System

The system was built around Peripheral Interface Controller (PIC) microcontroller 18F4550 to monitor and control the various parameters of baby incubators/radiant warmers. The system is able to transmit the different parameters of NICU continuously over long distance by using established wireless communication module.

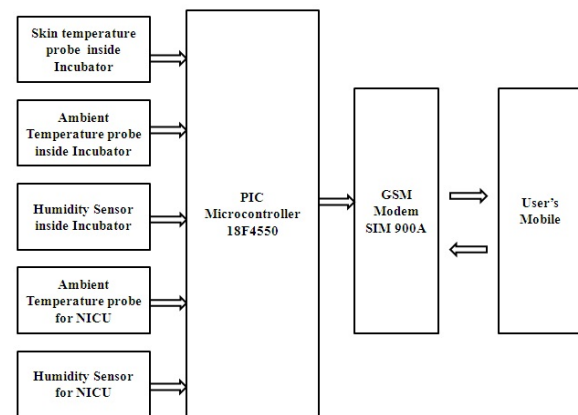

**Figure 1: Block Diagram of the System**

In case of baby incubators it is necessary to maintain the essential temperature around the baby. Usually the new born babies require warmer conditions as per their mother's womb. In case of premature babies the temperature should be maintained near about 34°C to 37°C.

Inside the incubator, the temperature monitoring system uses a skin-temperature probe to maintain baby's skin temperature about 36°C to 37°C. The air temperature-probe was also deployed to monitor the temperature around the baby. These sensors were producing analogue electrical signals with respect to temperature. The relative humidity of incubator was also monitored using the humidity sensor from SYHS2XX series. The same physical parameters i.e. temperature and relative humidity were also monitored in the NICU (outside the incubator) room.

The Fig. [1] Shows the block diagram of an embedded system consisting of three temperature sensors and two humidity sensors. In this case, one temperature probe was used to detect the skin

temperature of the infant. The second temperature sensor was used for monitoring the temperature inside incubator and the third temperature sensor was fixed outside the incubator to detect the temperature of the NICU room. Similarly one humidity sensor fixed inside the incubator was used to detect the relative humidity of it. And another humidity sensor was used to monitor the relative humidity of NICU room. The signal variation of all these sensors was given to Analogue to Digital Convertor (ADC), hosted in the PIC microcontroller device 18F4550 itself. The digitized information of NICU was transmitted through a wireless communication module towards the receiving end.

The system provides a wireless solution in which the NICU parameters; mentioned in above paragraphs, were monitored with the help of a Global System for Mobile Communications (GSM) modem, SIM900A. It sends the Short Message Service (SMS) to the physician's cellular phone and conveys the present values of temperatures and relative humidity. As per mentioned in the report given by the Rhydolabz [10], the deployed GSM modem runs on 3.3V or 5V TTL interfacing circuitry that allows direct interfacing with 5V Microcontrollers. Various Application Terminal (AT) commands supported by GSM modem were used for the present research work. These are as given below:

- AT+CMGF: To select SMS message format.
- AT+CMGS: To send a short message.
- AT+CMGD: To delete a short message from the GSM Module.

### 3. Software Development Flow

An Electronic Design Automation (EDA) tool, MikroC was used to compile and debug the source code developed for this research [11]. The Fig. 2 shows a flow diagram developed for the present research work.

A source code was developed to initialize the microcontroller port pins as analogue inputs. The UART was configured to send the data at the baud rate of 9600. The LCD module connections were defined. The A/D conversion was started with the setting of ADCON0 register. The digitized data of each sensor was stored in respective variables. Then the statuses of all the parameters were sent using GSM modem towards user's mobile with the help of AT commands.

The special-function registers available in the PIC microcontroller were used for serial communication between the microcontroller unit and GSM module.

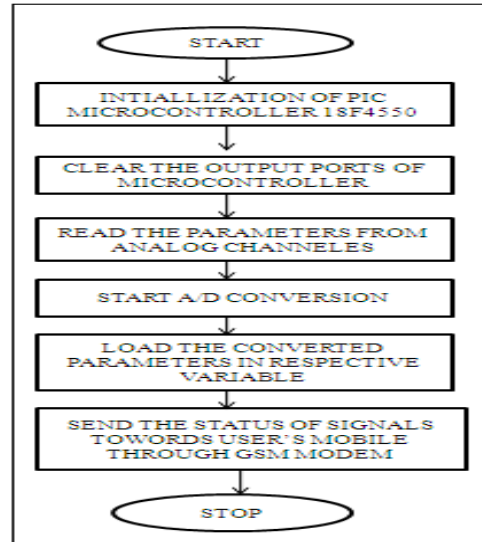

**Figure 2: Flow Diagram of the System**

The initialization of Analogue to Digital Converter (ADC) and Universal Synchronous and Asynchronous Receiver Transmitter (USART) is given as follows:

The USART was configured in the full duplex system that communicates with the peripherals like ADC, Digital to Analogue Converter (DAC), and serial Electrically Erasable Programmable Read Only Memories (EEPROMs). It was initialized with the help of instruction UART1\_Init (9600). The figure 9600 in bracket indicates the selected baud rate for data transmission.

To initialize the ADC module of microcontroller PIC, analogue channels were configured as inputs by setting the SFR i.e. ADCON register. The conversion clock was set to half of the oscillator frequency i.e. ( $F_{osc}/2$ ), and the conversion feature was powered up by loading 0x01 in ADCON0. The channel selection was done in the register ADCON1 by loading it with 0x0B as shown in the Fig.3.

ADCS1	ADCS0	CHS2	CHS1	CHS0	GO/DONE	—	ADON
0	0	0	0	0	0	0	1

**ADCON0 Register**

ADFM	ADCS2	—	—	PCFG3	PCFG2	PCFG1	PCFG0
0	0	0	0	1	0	1	1

ADCON1 Register

Figure 3: ADCON0 and ADCON1 register settings in PIC microcontroller for implementation of the research work

The parameters were displayed on the LCD at local level, and transmitted towards the user in the form of text message. AT commands were used for controlling the functionality of modem. The Fig.4 shows a circuit diagram of the system.

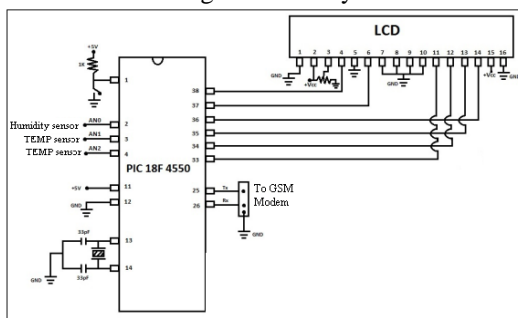

Figure 4: Circuit Diagram of the System

#### 4. Conclusion and Future Work

The present research work is the development of an embedded system for monitoring the temperature and humidity inside the incubator as well as NICU for new-born preterm/weak infants. These parameters were monitored remotely, using a GSM module.

As a future work, all the samples of the parameters can be stored and utilized for further diagnosis. The system can also be used for monitoring of more parameters along with introducing smart monitoring features, such as Liquid Crystal Displays (LCDs) with touch screen facility.

#### References

[1] YASEER AMER AI-TAWEEL (2006), "A Simulation Model of Infant - Incubator - Feedback System with Humidification and Temperature Control", Auckland University of Technology, Available from: <http://aut.researchgateway.ac.nz/bitstream/handle/10292/975/AITaweelY.pdf;jsessionid=C7FA521998729E73154FFA4151288F80?sequence=3>.

[2] CARLOS PATERMAIN SOLER, Supervisor: ABBAS KHUDAIR ABBAS (2011),

"Prototyping a closed loop control system for a neonatal incubator", Version:2009-11-28, Available from: <http://upcommons.upc.edu/pfc/bitstream/2099.1/9436/1/MAIN.pdf>.

[3] Available from: <http://www.newbornwhocc.org/ONTOP-ATA/Equipment-PDF/Radiant-Warmer/Radiant-Warmer-Job-aid.pdf>.

[4] FENG DONG-QING, ZHANG YU, LIU YA-LEI, (2009), "Design of Intelligent Monitor System Applied to Infant Incubator", Journal of Zhengzhou University Natural Science, Available from: [http://en.cnki.com.cn/Article\\_en/CJFDTOTAL-ZZDZ200902021.htm](http://en.cnki.com.cn/Article_en/CJFDTOTAL-ZZDZ200902021.htm).

[5] KRANTI DIVE, R. W. JASUTKAR (2011), "Infants monitoring by developing an Embedded Device for incubator", (IJAEST) International Journal of Advanced Engineering Sciences and Technologies, Vol No. 2, Issue No. 1, 068 – 072, Available from: <http://www.ijaest.iserp.org/archives/3-D16-31-10/Vol-No.2-Issue-No.1/IJAEST-vol-no.2-issue-no.1.pdf>.

[6] STINA CAXE (n.d.) "The Baby Sideshow: a History of the Incubator", Available from: <http://stinacaxe.hubpages.com/hub/caxe21incubator> or.

[7] Pediatric On call-Child Health Care, Available from: [http://www.pediatriconcall.com/fordocor/medical\\_equipment/Radiant\\_Warmer.asp](http://www.pediatriconcall.com/fordocor/medical_equipment/Radiant_Warmer.asp).

[8] D. C. SHAH and U. D. DALAL (2011), "Real time Wireless Data Acquisition and Fault Monitoring using DSP processor TMS320F2812 with CPLD interface", 2nd International Conference and workshop on Emerging Trends in Technology (ICWET) 2011, International Journal of Computer Applications (IJCA). PP 25-34, Available from: [www.ijcaonline.org/icwet/number7/CE349.pdf](http://www.ijcaonline.org/icwet/number7/CE349.pdf).

[9] (n.d.) Special care: ill or premature babies Available from: <http://www.nhs.uk/Conditions/pregnancy-and-baby/pages/baby-special-intensive-care.aspx#close>.

[10] Online: [www.rhydolabz.com](http://www.rhydolabz.com) > GSM/GPRS/GPS.

[11] Available from: <http://www.microchip.com/1010/index.htm>.



**N.S. Joshi**, born on 6<sup>th</sup> January 1981, is an Assistant Professor in Department of Electronics, Willingdon College, Sangli, Maharashtra, India. She is doing her Ph.D. in Electronics, under the faculty of Science, under the guidance of Dr P.K. Gaikwad, and co-guide Prof. (Dr.) R.K. Kamat at

Shivaji University, Kolhapur. India.