

## Game theory-based photovoltaic array system reconfigure method: experimental validation

Isha Kansal\* and Rupendra Kumar Pachauri

Department of Electrical and Electronics Engineering, School of Engineering, University of Petroleum and Energy Studies, Dehradun, India- 248007

Received: 03-August-2022; Revised: 19-February-2023; Accepted: 22-February-2023

©2023 Isha Kansal and Rupendra Kumar Pachauri. This is an open access article distributed under the Creative Commons Attribution (CC BY) License, which permits unrestricted use, distribution, and reproduction in any medium, provided the original work is properly cited.

### Abstract

*The performance of photovoltaic (PV) systems is significantly impacted by partial shading conditions (PSCs) when generating electricity. To mitigate these effects, researchers have explored modifying electrical connections and rearranging PV array modules. The primary goal of this research is to reduce shading's impact on PV systems and increase the global maximum power point (GMPP). In this study, the magic squares (MS) game puzzle (4×4 size) is used to demonstrate the PV system's performance, achieving 49.05W and 51.35W under realistic non-uniform irradiation levels. The total-cross-tied (TCT) and series-parallel (SP) methods are analyzed and compared, like the approach used in MS puzzles. Experimental validation shows good agreement with the MATLAB/Simulink analysis results in terms of low power loss (PL), GMPP locations, power enhancement (PE), and fill factor (FF). The results indicate that the suggested PV system is capable of producing satisfactory results.*

### Keywords

*Renewable energy, Solar energy, Global maximum power, Shading effect, Power loss.*

### 1.Introduction

This massive power outage that has gripped the nation encourages the development of sustainable energy systems, such as those based on solar, tides, geothermal, wind, and biofuels, among others [1]. Debilitating hydrocarbon deposits, as well as environmental issues, catalyse research into solar-powered systems [2–4]. Photovoltaic (PV) power generating system installations are increasing exponentially in urban areas today to supply power for industrial and domestic applications. Numerous factors influence PV system evaluation. Designers and installers face one of the most significant challenges when it comes to shade. In general, shading reduces system energy yield because of the shadow cast on rooftop PV panels [5].

Actual assessment factors such as power and voltage can be influenced by shadows on solar panels. This lowers the overall performance of the PV. Only a handful of documented instances of shadow negatively impacting system performance have been found.

Only a handful of documented instances of shadow negatively impacting system performance have been found, according to the author. Recently, observable technological advancements have become a major source of content for research into reforming the modular electrical connection of a PV system to improve its performance [6]. It is possible to construct a network using (either a series-parallel (SP) layout, a honeycomb (HC) layout, a total-cross-tied (TCT) layout, or a bridge-link (BL) layout) series-connected arrays of PV modules in [7], but module reorganisation techniques in an array, such as game-puzzle based, are used to improve performance.

Here, the PV system performance is shown by the magic square (MS) game puzzle (4×4 size) under both the realistic non- uniform irradiation levels. The author highlighted innovative work with the recommended modification of the system's layout to accommodate rearranged PV modules and subsequent verification through simulation and experiment and an exhaustive comparison is completed with the inspiration of the mentioned literature.

\*Author for correspondence

This manuscript contributes to the study of photovoltaic (PV) arrays by considering various shading scenarios to evaluate their performance. The proposed PV array reconfiguration is based on a puzzle approach, and is applied to analyze both series-parallel (SP) and total cross-tied (TCT) topologies. The performance of these configurations is evaluated by analyzing their power and current diagrams under four different degrees of partial shading conditions (PSCs). This analysis provides important performance parameters for PV arrays, which can inform future design and optimization efforts.

The puzzle-based design is recommended because of its ability to evenly distribute shade, which improves the PV array's performance in terms of power loss (PL), global maximum power point (GMPP), fill factor (FF), and performance ratio (PR). *Figure 1* shows how shading affects the efficiency of PV systems and the underlying cause.

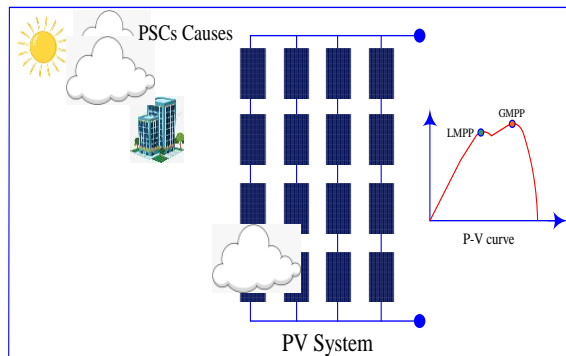

**Figure 1** Various shading conditions affecting PV performance

The structure of this work is divided into six main sections. Section 1 covers the background, motivation, and objectives of the study. In Section 2, we explore different variations in PV array configurations based on existing literature and their impact on performance parameters of solar PV systems. Section 3 provides an overview of the methodologies used to evaluate PV system performance under potential shading conditions. Section 4 describes in detail the simulation and experimental methods, including data acquisition, assessment, and real-time storage. It also presents a discussion of the performance outcomes under various shading conditions. Finally, Section 5 provides a summary of the study's findings and future scope for further research.

## 2.Literature review

In the manuscript, we have investigated different variants in PV array configurations based on available literature and their impact on performance parameters of solar PV system such as reliability, accuracy, optimized locations of GMPP, FF, minimum PL etc., the various research topics explored to further assessment are discovered and calculated. An ample of research article are treated for state of art review to comprehend study on entire PSCs discussed from performance evaluation of PV array system.

It has been observed in experimental analysis that multiple power points (MPP) are reduced compared to TCT, when modelled for similar size PV system. In accordance with [8], the author performed both simulations and experimental analysis to assess the performance of a 6×6 array both in the TCT and MS configuration, where the GMPP was observed to be 300W at a level of irradiation of 500-1000W/m<sup>2</sup> in the MS configuration. Using this technique in [9–12], the modules physical placement is preserved while modifications are made to the wiring system. A study is conducted to determine whether or not the proposed approach is effective by performing extensive simulations with varying degrees of shading, and then analysing the results with Current-Voltage (I-V) and power-voltage (P-V) plots. This is done so that the method can be demonstrated to be useful. In [13], author uses the odd-even (OE) method for rearranging conventional TCT methodology in order to disperse high shades on PV arrays. During the process of researching a novel OE configuration, it was discovered that power was increased for each of the four shading scenarios that were being considered. These scenarios were as follows: dwarf narrow, tall narrow, dwarf broad, and tall broad. When compared with SP, BL, and TCT, the results were as follows: 30.88%, 14.31%, 8.47%, and 2.18% respectively [14]. Under short narrow (SN), long wide (LW), and short wide (SW) shading scenarios, the authors' unique Skyscraper game puzzle-dependent PV arrangement was found to be the most effective, generating 43.36%, 22.36%, and 39.31% more power at GMPP, respectively, than a dominance square (DS)-based arrangement. PV arrays of both 9×9 and 5×5 sizes have been used to model and test this phenomenon.

In [15] the author investigated and observed that the power offered by recommended Su-Do-Ku (SDK) based bridge link- total cross tied (BL-TCT) arrangement at different irradiation levels is

44.314W. The author in [16] made a comprehensive look at how the PV system's flaws stem from erratic solar irradiance of 400-1000W/m<sup>2</sup> in traditional PV arrangements i.e., SP, HC, BL, TCT and the redesign method (RM). In [17], they have introduced and discussed an immensely shadow scattering technique using Rao, social mimic optimization (SMO) and flow regime algorithm (FRA) algorithm which has enhanced power compared for 9×9 dimension of TCT, competence square (CS) and genetic algorithm (GA) arrangement by 13%, 11%, and 9% respectively. Experiencing non-uniform three shading grades as 200W/m<sup>2</sup>, 400W/m<sup>2</sup>, 500W/m<sup>2</sup>, 600W/m<sup>2</sup> and 900W/m<sup>2</sup>, assessment domains such as mismatch loss (ML), %PL, %PE and FF with superior power with lowered maximum power point (MPP) for FRA are recognized. Compared to the SP configuration, the BL, LD, HC, TCT, bridge link-honey comb (BL-HC), and series parallel-total cross tied (SP-TCT) topologies enhanced output power by 1.2%, 1.8%, 3.2%, 3.4%, 3.3%, 3.1%, and 2.8%. In order to maximise power output while minimising shade distribution losses, voltage drop, and cable costs, this paper proposes a reconfiguration scheme [18–21]. The goal of this paper was to examine and contrast the results obtained by using a number of different reconfiguration schemes such as SP, TCT, OE, LU SHO, odd-even-prime (OEP), Sudoku, etc. to analyse their field applicability. The higher capital costs for cables, voltage drop, and PL more than cancel out the benefit of increased output current and power from various reconfiguration schemes.

New game puzzle, the ancient Chinese square matrix (ACMS), is proposed in [22] and compared to shading and PV array layouts. It has been demonstrated that if optimal GMPP performance is a concern, the ACMS-based setup is the clear winner and significantly reduced PL. Traditional (TCT, Ken-Ken, and L-Shape PV configurations) and creative permutation and combination (P-C) configurations (sizes 4×4, 4×6, and 9×9) influenced by the shadow effect were analysed in [23]. Shading conditions were also realistic, with irradiances ranging from 500 to 1000 W/m<sup>2</sup>. In addition, the novel P-C outperforms alternative methods in terms of GMPP efficiency. In [24], a PV module arrangement inspired by the 'Knight pattern' chess game symbol is used and compared to the standard power grid (SP, TCT, and Su-Do-Ku). There are six distinct shading schemes used in this study, each with a different irradiance level ranging from 200 to 950 watts per square metre. This study [25] compares SP, BL, HC, and TCT configurations to proposed game theory (PGT)

puzzle-based configurations under realistic PSCs. The PGT puzzle-based layout has fewer and higher power maxima spots than other PV array configurations. The shading case-II PGT configuration outperforms the SP, BL, HC, and TCT arrangements with GMPP, %PE, reduced PL, FF, and PR (%) values of 309.1 W, 9.84%, 95.9 W, 0.720, and 76.32%.

The optimal PV configuration is formed through dynamic manipulation [26] of the intermodular solid-state switches using a novel maximum power point tracking (MPPT) algorithm that takes into account the type of PSC patterns for PV arrays, the switching process is simulated in great detail. When compared to an ideal switch-based circuit, the P-V characteristics of the IGBT-based circuit were found to be very similar, and the switching losses of the arrays across all reconfiguration modes ranged from 0.87 percent to 2.34 percent. We compare the new LS-SRA and HS-SRA configurations to the established SP, TCT, Su-Do-Ku (SDK), and I-SDK based PV setups under realistic PSCs [27]. In [28] four square (FS) is a novel static reconfiguration [29–32] approach that is suggested. FS is suggested as a general strategy for distributing various shade patterns. A number of static and dynamic reconfiguration methods are compared to FS. The reliability of the FS is evaluated by calculating the daily energy savings. FS increased the power when there were sporadic failed modules by 38.016%. In comparison to the TCT-connected system, it achieves the best redesign [33], increasing the power by percentages of 44.42%, 11.9%, 33.36%, 20.86%, and 13.17%. The proposed approach increases power output by 47.2% for the S-P configuration [34] and is 10.45%, 30.75%, 17.25%, and 26.27% more efficient. By combining the Multi-Slice Array layout with the differential evolution-based adaptive perturb and observe (DEAPO) MPPT technique in this work [35] to present a novel hybrid approach that addresses the aforementioned issue. With the help of a current compensation converter, the PV system can be run with evenly distributed rows of power generation in [36]. For the benefit of researchers working in this field, these papers [37–40] provides insights into recent developments in PV array configurations as well as their anticipated trends.

This research introduces a cutting-edge methodology for constructing various models of PV array placements to lessen the impact of shade. Configurations are described and discussed from the perspectives of advantages, shortcomings, and

essential aspects. In order to assess the different PV configurations based on topology, modelling, performance, scalability, grid connectivity, etc., a thorough literature review on the subject is conducted.

### 3. Methodology of Solar PV technology

#### 3.1 PV modelling

Solar PV cells are used to their full potential to produce increased rating loads by arranging them in series and parallel. Figure 2 depicts the electrically arranged circuit configuration of a solar PV cell.

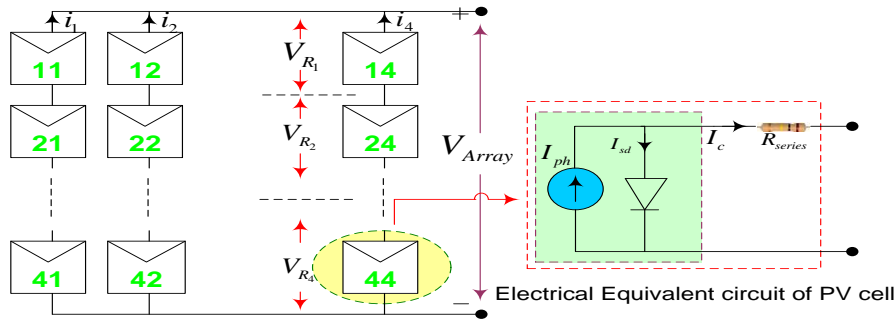

Figure 2 PV array development (4x4 size) and PV cell equivalent electrical circuit

Output voltage of the array depicted in Figure 3 can be expressed with the Equation 1 as,

$$V_C = \frac{AkT_c}{e} \ln \left( \frac{I_{ph} + I_o - I_c}{I_o} \right) - R_{series} I_c \quad (1)$$

Where,  $V_C$  and  $A$  are used to reflect the cell voltage and ideality factor respectively.  $T_c$  stands for cell temperature and  $e$  electron charge. Moreover,  $I_{ph}$  and  $I_o$  are represented as photo current and saturation current respectively. In addition,  $R_{series}$  and  $I_c$  stand for the series resistance and PV cell current.

#### (a) Conventional PV array configurations

In the SP topology, the finite numbers of panels are arrayed in a PV array strings (single) to enhance the voltage level. The parallel arrangement of PV strings in an array is directly responsible for elevating the current rating. Furthermore, cross-tied connections are arranged to modify the SP connections, and the newly developed PV array model is called TCT. Figure 3(a) makes it abundantly clear that the PV module with the numbers 22 (second row, second column) actually resides in the first and subsequent second rows. Therefore, all PV panels in an array system are treated with the same level of uniformity in terms of methodology. The conventional SP and TCT are electrically connected as a 44-size PV array, as shown in Figure 3.

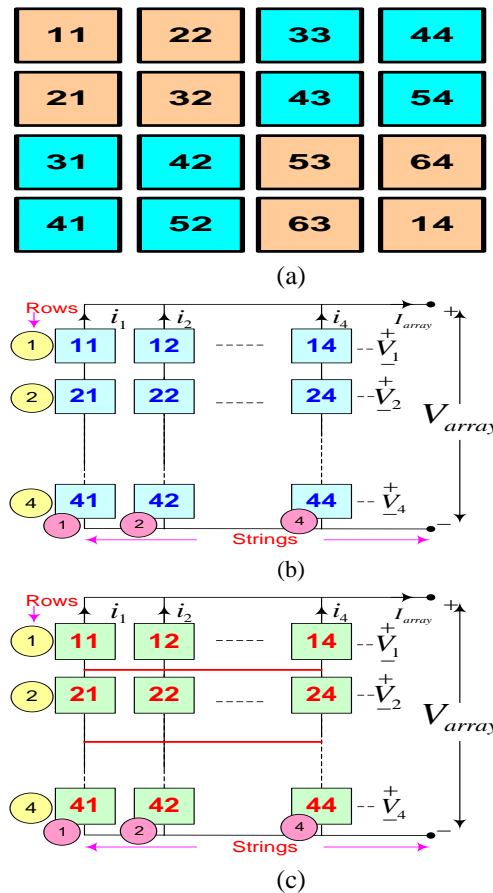
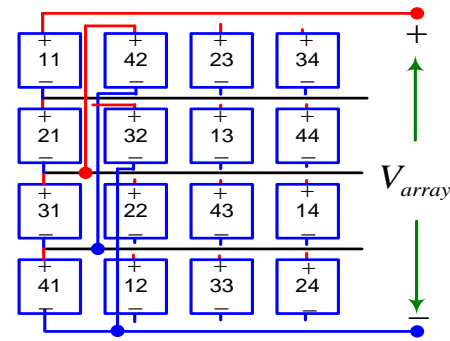
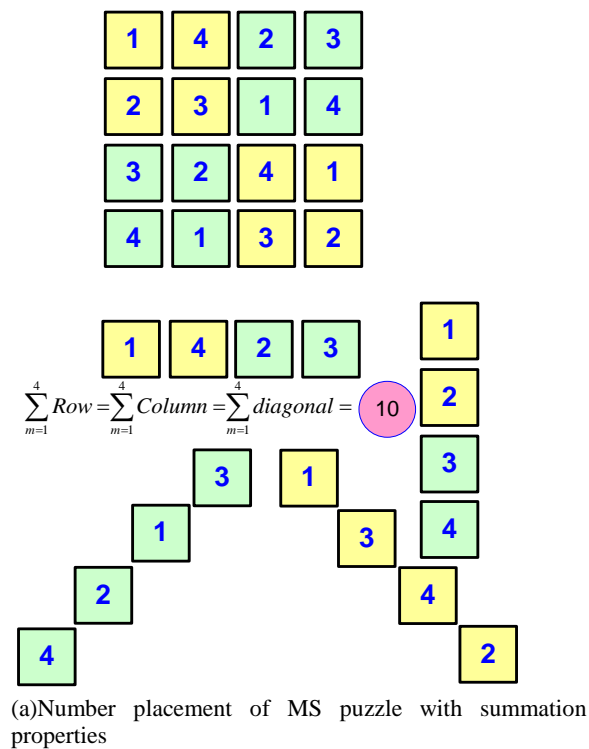

Figure 3 (a) Nomenclature 4x4 size PV array (b) SP (c) TCT arrangements

**(b)PV array configurations based on game puzzles: MS**

The foundation of the proposal is a particular ordering of integers from 1 to 4. In this study, a MS-based puzzle is taken into account for extensive study of the GMPP locations, PL analysis, and %PE under shading scenarios.

Furthermore, the methodology to obtain the MS puzzle with the equality summation properties, e.g., row, column, and diagonal, is given in Figure 4. The nomenclature and electrical arrangements of modules are explored to design an MS puzzle (4x4 size)-based PV array system. The generalised flow chart-based algorithm is given as,



(c)Electrical arrangement of PV array

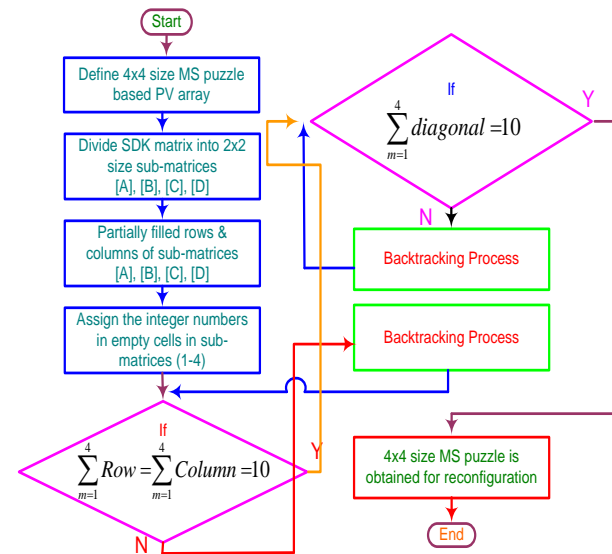

(d)Flow chart operation to design MS

**Figure 4** Methodology of attaining (4x4 Size) PV array configuration puzzle requiring MS

**3.1.1 Experimental setup**

The current experimental setup is meant for a thorough investigation of the performance of PV systems while using PSCs. The four-by-four size PV array is equipped with a voltage-current meter and a load-changing device for use in situations with variable resistive loads (DAS). Experiment setup as seen on the lab bench (Figure 5). A network of analogue sensors (voltage and current) linked to a microcontroller system forms the basis for a data logger system that can measure electrical performance in the dark and collect data in real time. Another stage of testing involves storing the system's performance characteristics for P-V and I-V characterization on a micro-SD card. As shown in Figures 6 and Figure 7, the DAS's data flow and wiring configuration are depicted for illustrative purposes.



Figure 5 Experimental setup

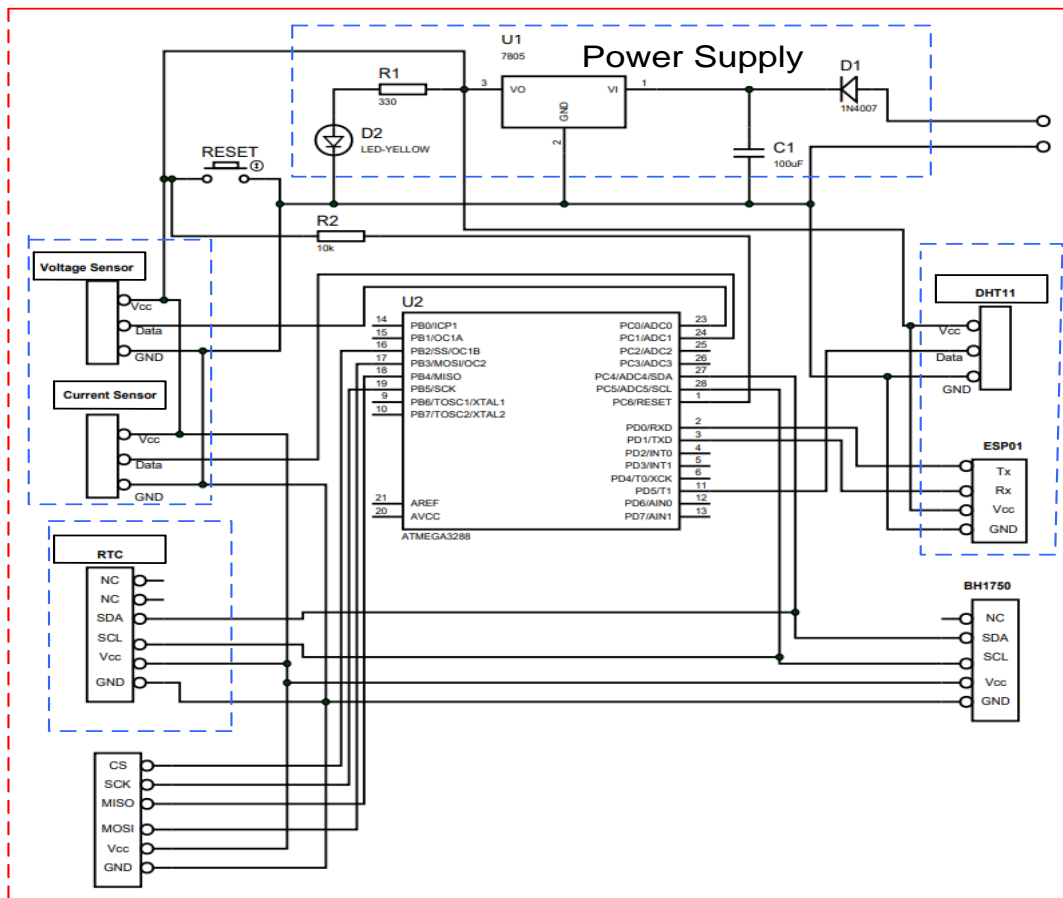

Figure 6 wiring arrangement of DAS for real time measurement

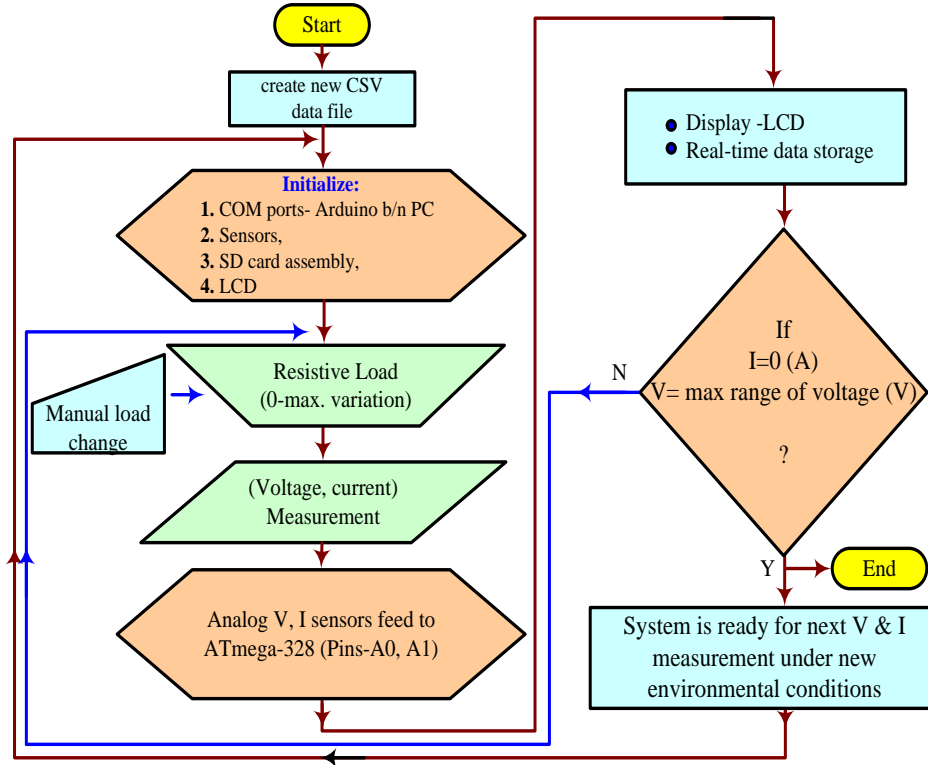

Figure 7 Schematic depiction of the data logging system's workflow

### 3.2 Performance parameters and shading scenarios

Because of PSCs, each module within an array has its own local power maxima point (LMPP) and GMPP on the P-V graph. Due to the presence of many GMPP and LMPP, the MPPT system may be deceived in the current shading environment and will be unable to achieve enhanced power to the load. To derive the performance characteristics, the nature of the I-V and P-V curves is depicted as follows:

**Power and voltage at GMPP ( $(P_{GMPP}) (V_{GMPP})$ )**  
 $(P_{GMPP})$  is the ultimate value measured under the shading conditions on P-V graphs. Furthermore, the voltage attained at GMPP is known as  $(V_{GMPP})$ .

#### FF

The FF is used to determine the performance efficiency of a P-V system and can be expressed as follows by Equation 2,

$$\%FF = \left( \frac{P_{GMPP}}{V_{OC} \times I_{SC}} \right) \times 100 \quad (2)$$

#### PL

PL can be evaluated through sum total of power at GMPP minus power at its ideal level. The identification of PL is expressed in Equation 3 as,

$$PL = P_{ideal} - P_{GMPP} \quad (3)$$

#### Execution ratio(ER)

Equation 4 expresses ER as a ratio in between power output at GMPP and that of a PV plant system at full capacity.

$$\%ER = \left( \frac{\text{Power at GMPP}}{\text{Rated power capacity}} \right) \times 100 \quad (4)$$

#### Power enhancement (PE)

The improvement in power for the advanced PV arrangement w.r.t the conventional arrangement is called PE. % PE is expressed in Equation 5 as,

$$\%PE = \left( \frac{P_{\text{advanced PV array}} - P_{SP}}{P_{SP}} \right) \times 100 \quad (5)$$

#### 3.2.1 Shading scenarios

For efficient performance investigation of PV systems in reference to FF, PL, % ER, and GMPP locations under two shading scenarios. These following shading circumstances have been used in this investigation, as illustrated in *Figure 8* and *Figure 9*,

Using Equations 6–8, we can theoretically evaluate the row-by-row current generated by SP-based PV array configurations in the shading case I.

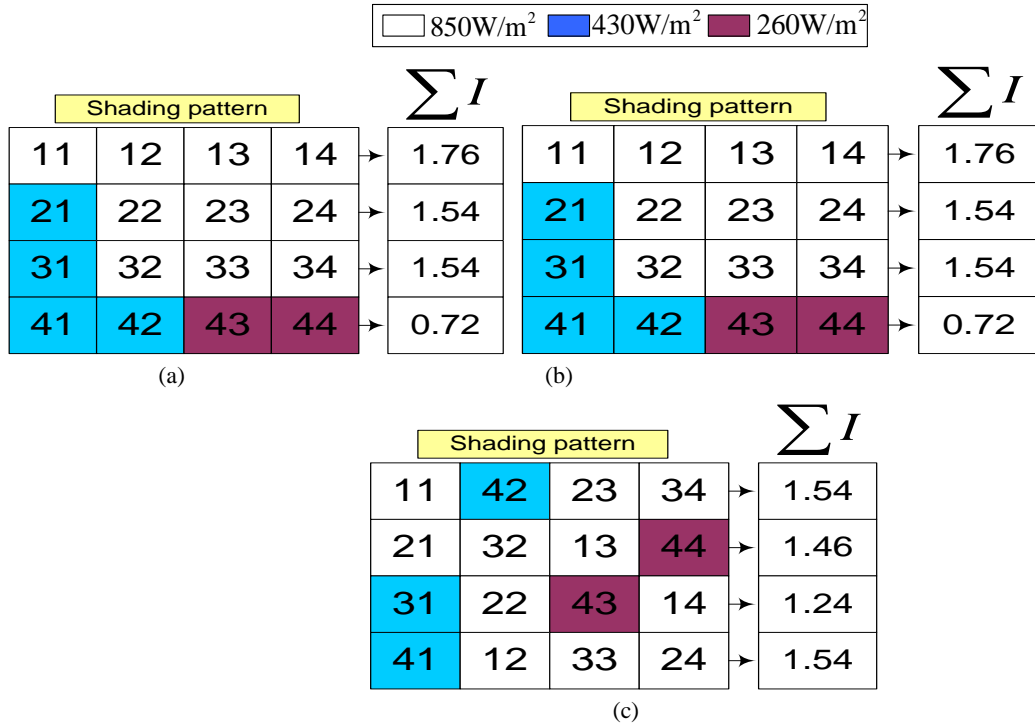

Figure 8 Shade profiles from reconfigured PV array

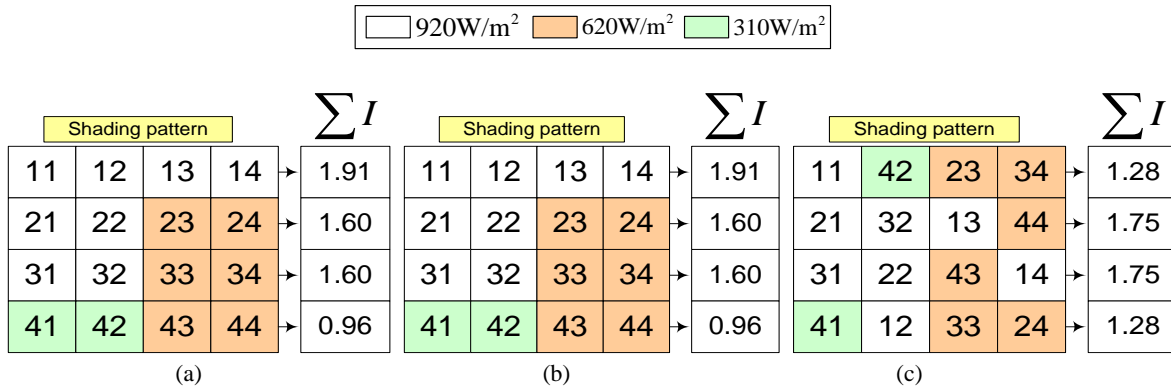

Figure 9 Shade profiles based on redesign PV array

$$I_{r1} = \left(\frac{850}{1000}\right)I_m + \left(\frac{850}{1000}\right)I_m + \left(\frac{850}{1000}\right)I_m + \left(\frac{850}{1000}\right)I_m = 3.4I_m \quad (6)$$

$$I_{r2} = I_{r3} = \left(\frac{430}{1000}\right)I_m + \left(\frac{850}{1000}\right)I_m + \left(\frac{850}{1000}\right)I_m + \left(\frac{850}{1000}\right)I_m = 3.4I_m \quad (7)$$

$$I_{r4} = \left(\frac{430}{1000}\right)I_m + \left(\frac{430}{1000}\right)I_m + \left(\frac{260}{1000}\right)I_m + \left(\frac{260}{1000}\right)I_m = 3.4I_m \quad (8)$$

Under the shadowing situation II, Equations 9–11 provide a theoretical evaluation of current for row-wise SP-based generated PV array designs.

$$I_{r1} = \left(\frac{920}{1000}\right)I_m + \left(\frac{920}{1000}\right)I_m + \left(\frac{920}{1000}\right)I_m + \left(\frac{920}{1000}\right)I_m = 3.68I_m \quad (9)$$

$$I_{r2} = I_{r3} = \left(\frac{920}{1000}\right)I_m + \left(\frac{920}{1000}\right)I_m + \left(\frac{620}{1000}\right)I_m + \left(\frac{620}{1000}\right)I_m = 3.08I_m \quad (10)$$

$$I_{r4} = \left(\frac{310}{1000}\right)I_m + \left(\frac{310}{1000}\right)I_m + \left(\frac{620}{1000}\right)I_m + \left(\frac{620}{1000}\right)I_m = 1.86I_m \quad (11)$$



As similar above analysis to identify the theoretical current for MS based PV array can be done under shading scenarios I-II.

### 4.Results and discussion

The implications of these shading schemes on performance for various array configurations are investigated in the following research.

#### 4.1Standard test conditions(STCs) P-V and I-V curves

According to simulation study, the maximum power and voltage of an array system at STC are 80.09W and 35.55V, respectively as depicted in *Figure 10*.

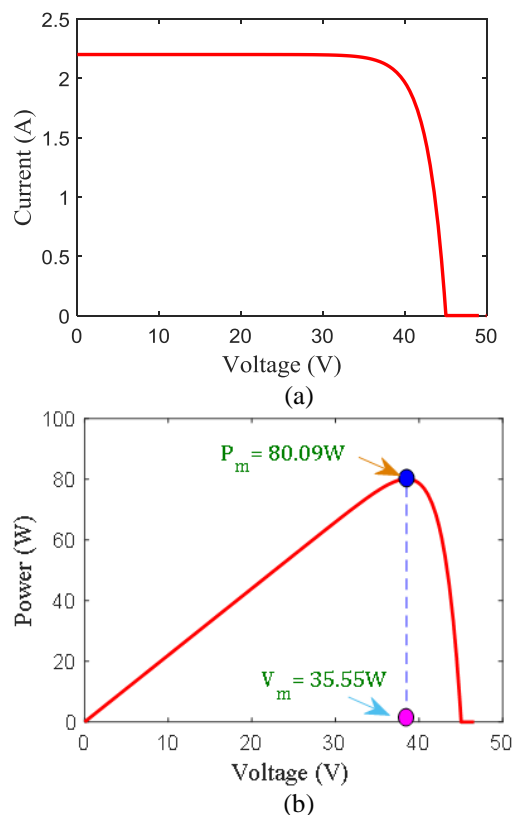

Figure 10 (a) I-V (b) P-V plots at STC

#### 4.2MATLAB/Simulink study: I-V and P-V plots under shade scenarios I-II

The I-V characteristics of MS are much smoother compared to those of SP and TCT designs, as seen in *Figure 11(a)*. It is observed that the short circuit current is 1.87 A, 1.87 A, and 1.63 A for SP, TCT, and MS, respectively.

The SP and TCT are incoherent due to the GMPP of the array and the module's maximum output power arrangements suffer considerable shading losses. Under shading scenario-I, the GMPP position is 210

found to be higher, at 49.05W, than the SP and TCT arrangements, which are 43.4W and 43.9W, respectively.

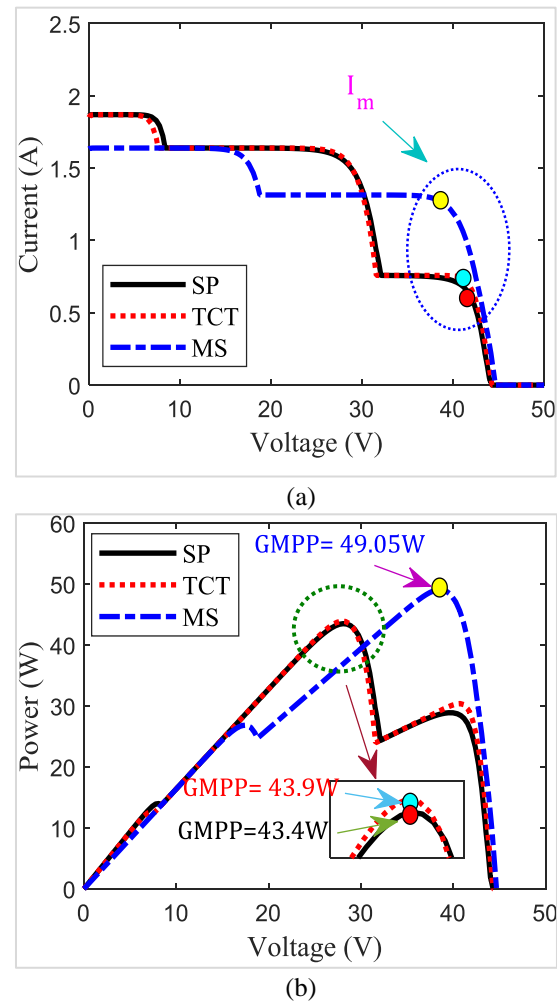
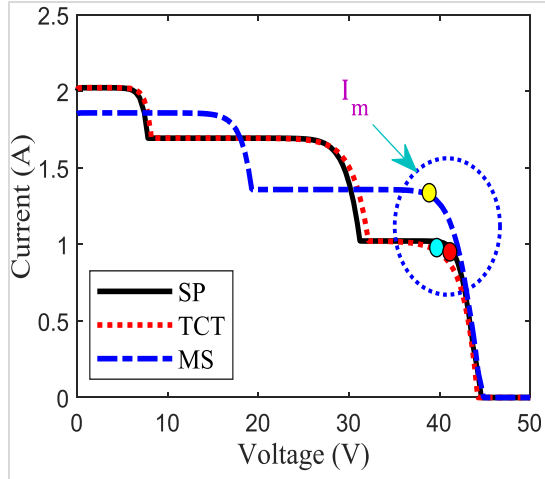
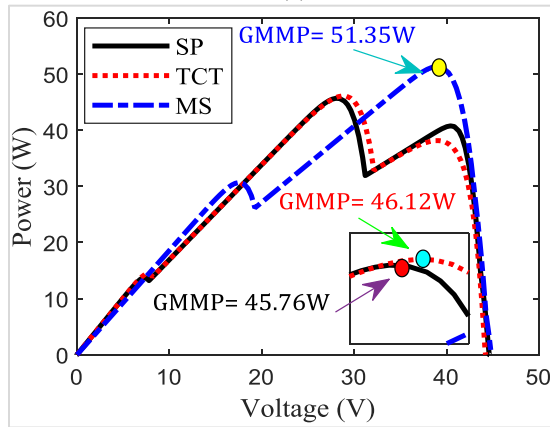

Figure 11 I-V and P-V plots under shading case-I

In comparison to SP and TCT configurations, reliable behaviour of I-V characteristics for MS is achieved in shading scenarios -II. In-depth analysis of the results of the SP, TCT, and MS array models revealed that SP and TCT have low power performance of 45.76W and 46.12W, respectively, compared to MS's 51.35W. I-V and P-V curves are depicted in *Figure 12* under shade scenario II.



(a)



(b)

**Figure 12** I-V and P-V plot under shading scenario-II

The assessment outcomes obtained through MATLAB/Simulink study are depicted in *Table 1*. The obtained performance indices are identified during the shading scenarios I-II as,

**Table 1** Quantitative performance indices during MATLAB/Simulink study

	Shading pattern-I		
	SP	TCT	MS
$P_{GMPP}(W)$	43.4	43.9	49.05
$V_{GMPP}(V)$	28.05	28.31	38.82
$I_m(A)$	1.54	1.55	1.26
$V_{OC}(V)$	43.8	44	44.4
$I_{SC}(A)$	1.87	1.87	1.63
%FF	53.0	53.3	67.8
PL(W)	36.69	36.19	31.04
ER%	54.18	54.81	61.24
%PE w.r.t.SP	-	1.15	13.01
$P_{GMPP}(W)$	45.76	46.12	51.35
$V_{GMPP}(V)$	27.91	28.73	39.12
$I_m(A)$	1.63	1.60	1.31

	Shading pattern-I		
	SP	TCT	MS
$V_{OC}(V)$	43.6	43.6	43.7
$I_{SC}(A)$	2.02	2.02	1.85
%FF	52.0	52.4	63.5
PL(W)	34.33	33.97	28.74
ER%	57.13	57.85	64.11
%PE w.r.t.SP	-	0.78	12.21

**4.3 Experimental validation: I-V plot and P-V plot for shade scenario-I**

An experimental investigation was done on 4x4 dimension SP, TCT and MS arrangement-based PV systems. Power at GMPP is calculated as 80.09W under standard solar irradiation of 1000W/m<sup>2</sup>. The significance of shading is shown through electrical parameters performance for all configurations i.e., SP, TCT and MS considered shown in *Table 2*. Under shading scenarios, as depicted in *Figure 13* of cases I, power maxima at MPP for SP, TCT and MS is observed as 42.38W, 42.65W and 46.01W respectively. MS configuration experiences smoother I-V characteristics as compared to TCT and SP. The value of short circuit current so observed is noted as 1.60A for MS under extensive examination in shading scenario-I.

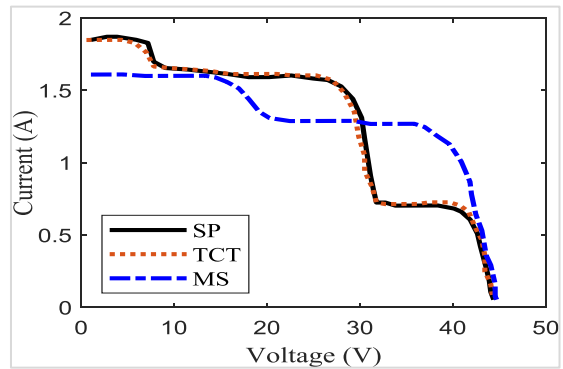

(a)

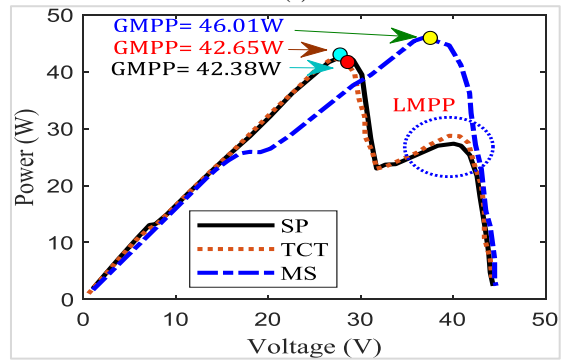

(b)

**Figure 13** I-V and P-V plots under shading scenario-I

The assessment outcomes obtained through experimentation study are depicted in *Table 2*. The obtained performance indices are identified during the shading scenarios-I as,

**Table 2** Quantitative performance indices in experimental analysis

	Shading pattern-I		
	SP	TCT	MS
$P_{GMPP}(W)$	42.38	42.65	46.01
$V_{GMPP}(V)$	26.97	27.92	36.89
$I_m(A)$	1.571	1.527	1.24
$V_{OC}(V)$	42.8	43.2	43.3
$I_{SC}(A)$	1.84	1.84	1.60
$FF$	53.8	53.6	66.4

	Shading pattern-I		
	SP	TCT	MS
$PL(W)$	37.71	37.44	34.08
$\%ER$	52.91	53.25	57.44
$\%PE$ w.r.t.SP	-	0.63	8.56

The transient analysis of electrical performance characteristics like GMPP's power and voltage is noticed during the experimentation work in order to validate the acquired results. Maximum current, voltage, and power are reduced from ideal/rated power (67.37W) to 42.38W (SP), 42.65W (TCT), and 46.01W (MS) under shade pattern-I, as illustrated in *Figure 14*.

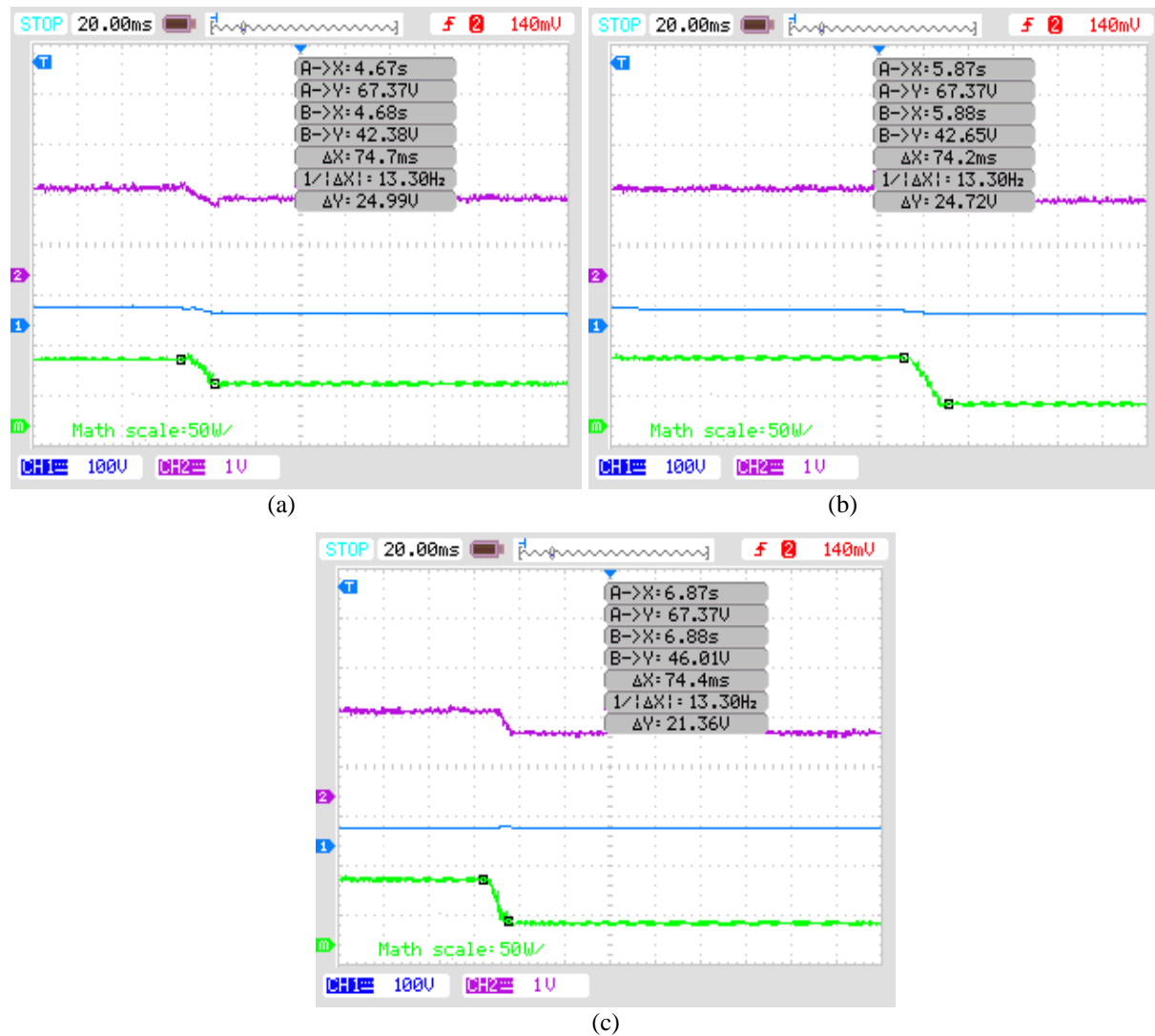
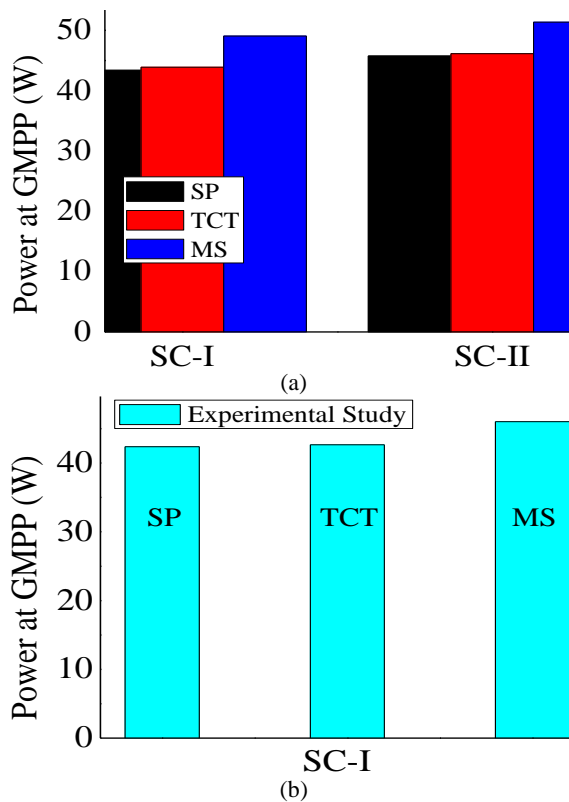

**Figure 14** Transient study of (a) SP (b) TCT (c) MS PV configurations under shading case-I

**4.4 Power at GMPP**

Power assessment results are depicted through *Figure 15*. While doing MATLAB/Simulink study shown in *Figure 15(a)*, it has been found out that MS topology with two shadowing scenarios I-II has highest power maxima at GMPP noted as 49.05W and 51.35W respectively.

In addition to this, when same MS arrangement undergoes electrical analysis experimentally under shadowing scenarios-I as depicted in *Figure 15(b)* denoted power at GMPP as 46.01W superior than TCT and SP as 42.65W and 42.38W as referred in *Table 2*.

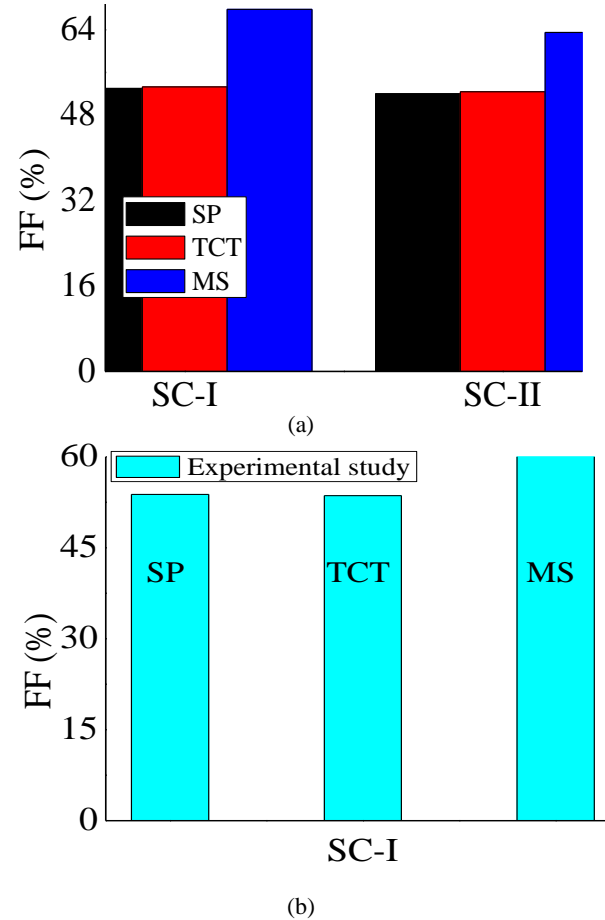

**Figure 15**  $P_{GMPP}$  after (a) Simulation study (b) Experimental analysis

**4.5 FF analysis**

On comparing MS with TCT and SP configuration, differences are observed in the FF among the three as shown through *Figure 16(a)*. During simulation study represented in shading scenarios I-II, shows high improvement in shading efficacy (FF) with MS as 67.8% and 63.5% referred to *Table 1* while TCT and SP stays at 53.3% and 53.0% for case-I and 52.4% and 52% for shading case-II respectively.

An experimental study was also conducted simultaneously for shading case-I, to validate MS array's performance. As a result of study conducted, MS array %FF is found to be 66.4% represented as bar chart in *Figure 16 (b)*.



**Figure 16** FF for (a) MATLAB/Simulink study (b) Experimental study

**4.6 PL analysis**

PL owing to shading given by diverse sources on PV systems such as SP, TCT, and MS game puzzle-based arrangements are evaluated in the experimental analysis study and MATLAB/Simulink study. The MS model offers minimum losses in power of 31.04W and 28.74W referred to *Table 1* under cases-I and II respectively. Bar chart analysis shown in *Figure 17(a)* and *Figure 17 (b)* reveals the same for MS configuration.

According to experimental analysis, MS has highest losses of 34.08W during case-I as shown in *Table 2* after performance validation is shown through *Figure 17(b)*.

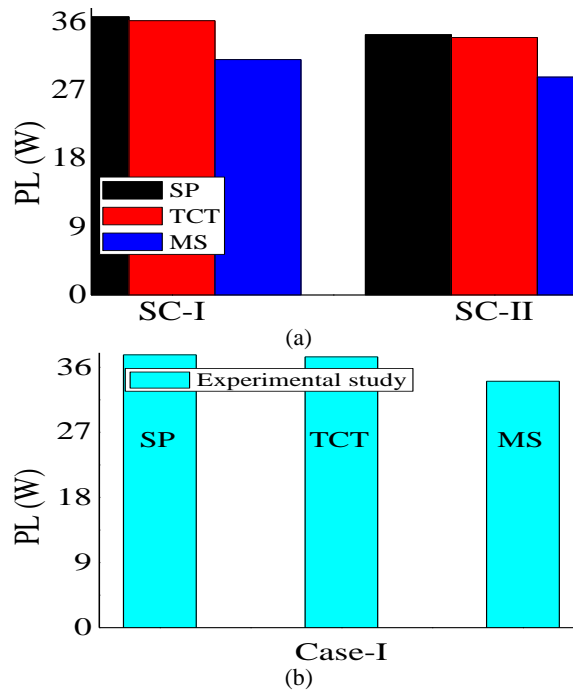

Figure 17 PL for (a) MATLAB/Simulink study (b) Experimental study

#### 4.7 ER and PE analysis

On comparing the experimental study with MATLAB/Simulink study, validated ER for MS is superior for both the shading cases of TCT and SP, resulting in performance enhancement as shown in Figure 18(a). Under shading cases I-II, ER% for MS is noticed to be much enhanced as 61.24% and 64.11% compared to conventional configurations as TCT (54.81% and 57.85%) and SP (54.18% and 57.13%) as referred to Table 1.

In experimental analysis, ER for MS is represented as bar chart depicting in Figure 18(b) has higher value as 57.44% (referred to Table 2), when investigated against SP and TCT.

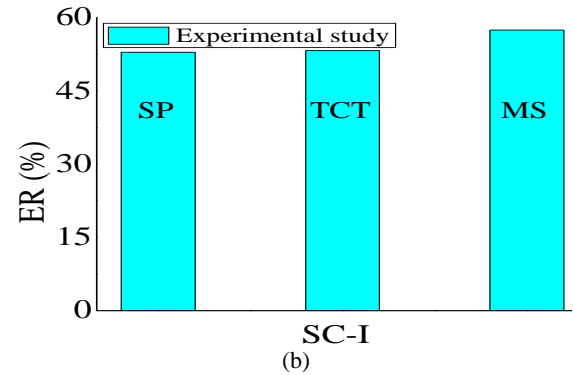
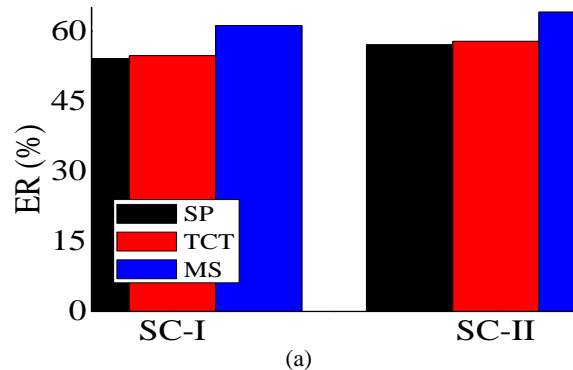

Figure 18 ER analysis for (a) MATLAB study (b) Experimental study

The performance improvement in relation to the SP array configuration is depicted in a bar graph throughout Figure 19 and is summarized in Table 1. The PE is raised in cases I and II from 1.15 % in TCT to 13.01 % in MS and also from 0.78 % in TCT to 12.21 % in MS, respectively. Furthermore, when experimentally analysed results in an increase of 0.63% in TCT to 8.56% in MS w.r.t SP as referred to Table 2 and represented by Figure 19(b).

#### 4.8 Performance outcomes: challenges & future scope

The primary goal is to encourage a strategy to lessen the effects of PV systems shadowing and achieve significant GMPP. Here,

- The MS game puzzle of 4×4 size illustrates the PV system performance at higher side under realistic non-uniform irradiation levels.
- These puzzle-based configurations when switched to larger scale matrices shows complexity in wiring connections then metaheuristic approaches are used to identify optimal GMPP for system efficiency.

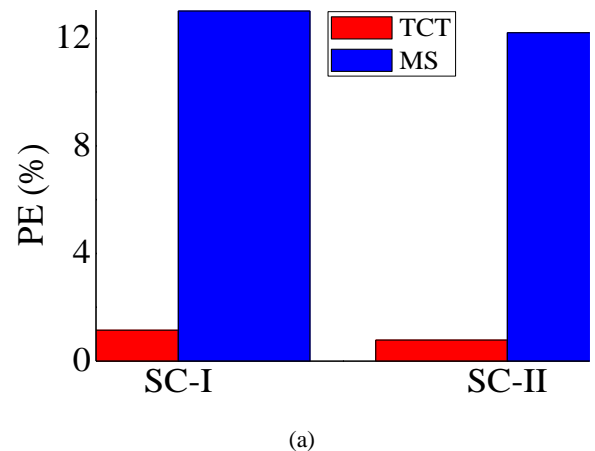

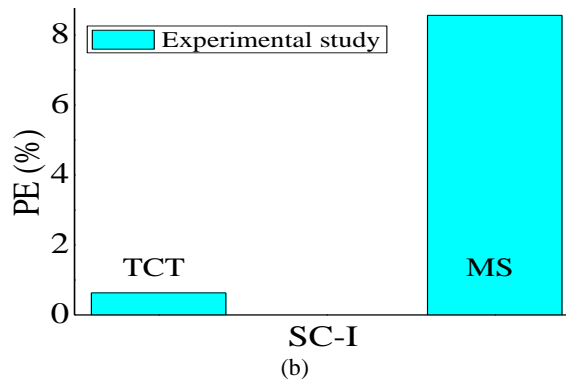

**Figure 19** PE analysis for (a) MATLAB (b) experimental study

In this manuscript, we compare and analyze conventional SP and TCT puzzle-based configurations with uniquely generated MS configurations under PSCs with respect to PL, FF, ER, and PE. Our extensive analysis indicates that the minimum power maxima point of PV arrays based on the MS puzzle is superior to that of alternative designs. Consequently, we have been able to reduce the negative impact of shading on the output of the PV system.

A complete list of abbreviations is shown in *Appendix I*.

## 5. Conclusion

In this manuscript, we compared and analyzed standard SP and TCT-based puzzle configurations with a uniquely generated MS configuration under PSCs. We validated our results extensively using MATLAB/Simulink-based experimentation and examined several performances measuring variables, including PL, FF, ER, and PE. Our research indicates that the MS puzzle-based array architecture presented has a minimum power maximum point with superior values.

In our rigorous MATLAB/Simulink study and experiment, we found that performance metrics estimated and discovered, such as power at GMPP, % PE, FF, and reduced PL (%), were considerably better for the MS puzzle-based PV array design compared to TCT and SP. Specifically, we found values of 49.05 W, 13.01%, 67.8%, and 31.04% respectively for the MS puzzle-based design, which were validated experimentally and found to be similar (46.01 W, 8.56%, 66.4%, and 34.08%).

Furthermore, we found that the MS puzzle-based array design outperforms other shading scenarios in

simulation, with power at GMPP, PE, FF, and insignificant PL values of 51.35 W, 12.21%, 63.5%, and 28.74%. We believe that our investigation will benefit future commercial PV plant analysts and newcomers to this sector.

## Acknowledgment

None.

## Conflicts of interest

The authors have no conflicts of interest to declare.

## Author's contribution statement

**Isha Kansal:** Conceptualization, methodology visualization and writing-editing. **Rupendra Kumar Pachauri:** Editing, visualization and supervision.

## References

- [1] Pareek S, Dahiya R. Enhanced power generation of partial shaded photovoltaic fields by forecasting the interconnection of modules. *Energy*. 2016; 95:561-72.
- [2] Sahu HS, Nayak SK, Mishra S. Maximizing the power generation of a partially shaded PV array. *IEEE Journal of Emerging and Selected Topics in Power Electronics*. 2015; 4(2):626-37.
- [3] Rakesh N, Madhavaram TV. Performance enhancement of partially shaded solar PV array using novel shade dispersion technique. *Frontiers in Energy*. 2016; 10(2):227-39.
- [4] Sahu HS, Nayak SK. Extraction of maximum power from a PV array under nonuniform irradiation conditions. *IEEE Transactions on Electron Devices*. 2016; 63(12):4825-31.
- [5] Pareek S, Chaturvedi N, Dahiya R. Optimal interconnections to address partial shading losses in solar photovoltaic arrays. *Solar Energy*. 2017; 155:537-51.
- [6] Vengatesh RP, Rajan SE. Analysis of PV module connected in different configurations under uniform and non-uniform solar radiations. *International journal of Green Energy*. 2016; 13(14):1507-16.
- [7] Belhaouas N, Cheikh MS, Agathoklis P, Oularbi MR, Amrouche B, Sedraoui K, et al. PV array power output maximization under partial shading using new shifted PV array arrangements. *Applied Energy*. 2017; 187:326-37.
- [8] Malathy S, Ramaprabha R. Reconfiguration strategies to extract maximum power from photovoltaic array under partially shaded conditions. *Renewable and Sustainable Energy Reviews*. 2018; 81:2922-34.
- [9] Babu TS, Ram JP, Dragičević T, Miyatake M, Blaabjerg F, Rajasekar N. Particle swarm optimization based solar PV array reconfiguration of the maximum power extraction under partial shading conditions. *IEEE Transactions on Sustainable Energy*. 2017; 9(1):74-85.
- [10] Pillai DS, Ram JP, Nihanth MS, Rajasekar N. A simple, sensorless and fixed reconfiguration scheme for maximum power enhancement in PV systems.

- Energy Conversion and Management. 2018; 172:402-17.
- [11] Madhusudanan G, Senthilkumar S, Anand I, Sanjeevikumar P. A shade dispersion scheme using Latin square arrangement to enhance power production in solar photovoltaic array under partial shading conditions. *Journal of Renewable and Sustainable Energy*. 2018; 10(5):1-14.
- [12] Krishna GS, Moger T. Improved SuDoKu reconfiguration technique for total-cross-tied PV array to enhance maximum power under partial shading conditions. *Renewable and Sustainable Energy Reviews*. 2019; 109:333-48.
- [13] Nasiruddin I, Khatoun S, Jalil MF, Bansal RC. Shade diffusion of partial shaded PV array by using odd-even structure. *Solar Energy*. 2019; 181:519-29.
- [14] Nihanth MS, Ram JP, Pillai DS, Ghias AM, Garg A, Rajasekar N. Enhanced power production in PV arrays using a new skyscraper puzzle based one-time reconfiguration procedure under partial shade conditions (PSCs). *Solar Energy*. 2019; 194:209-24.
- [15] Sagar G, Pathak D, Gaur P, Jain V. A Su Do Ku puzzle based shade dispersion for maximum power enhancement of partially shaded hybrid bridge-link-total-cross-tied PV array. *Solar Energy*. 2020; 204:161-80.
- [16] Gul S, Ul HA, Jalal M, Anjum A, Khalil IU. A unified approach for analysis of faults in different configurations of PV arrays and its impact on power grid. *Energies*. 2019; 13(1):1-23.
- [17] Babu TS, Yousri D, Balasubramanian K. Photovoltaic array reconfiguration system for maximizing the harvested power using population-based algorithms. *IEEE Access*. 2020; 8:109608-24.
- [18] Premkumar M, Subramaniam U, Babu TS, Elavarasan RM, Mihet-popa L. Evaluation of mathematical model to characterize the performance of conventional and hybrid PV array topologies under static and dynamic shading patterns. *Energies*. 2020; 13(12):1-37.
- [19] Kour J, Shukla A. Comparative analysis of different reconfiguration schemes for power enhancement under various shading scenarios. *Solar Energy*. 2021; 230:91-108.
- [20] Satpathy PR, Babu TS, Shanmugam SK, Popavath LN, Alhelou HH. Impact of uneven shading by neighboring buildings and clouds on the conventional and hybrid configurations of roof-top PV arrays. *IEEE Access*. 2021; 9:139059-73.
- [21] Varma GH, Barry VR, Jain RK. Reconfiguration TCT array strategy for superior performance of PV water pumping system. In *national power electronics conference 2021* (pp. 1-6). IEEE.
- [22] Pachauri RK, Thanikanti SB, Bai J, Yadav VK, Aljafari B, Ghosh S, et al. Ancient Chinese magic square-based PV array reconfiguration methodology to reduce power loss under partial shading conditions. *Energy Conversion and Management*. 2022.
- [23] Mishra VL, Chauhan YK, Verma KS. A novel PV array reconfiguration approach to mitigate non-uniform irradiation effect. *Energy Conversion and Management*. 2022.
- [24] Cherukuri SK, Kumar BP, Kaniganti KR, Muthubalaji S, Devadasu G, Babu TS, et al. A novel array configuration technique for improving the power output of the partial shaded photovoltaic system. *IEEE Access*. 2022; 10:15056-67.
- [25] Pachauri RK, Motahhir S, Gupta AK, Sharma M, Minai AF, Hossain MS, et al. Game theory based strategy to reconfigure PV module arrangements for achieving higher GMPP under PSCs: Experimental feasibility. *Energy Reports*. 2022; 8:10088-112.
- [26] Yadav VK, Yadav A, Yadav R, Mittal A, Wazir NH, Gupta S, et al. A novel reconfiguration technique for improvement of PV reliability. *Renewable Energy*. 2022; 182:508-20.
- [27] Aljafari B, Satpathy PR, Thanikanti SB. Partial shading mitigation in PV arrays through dragonfly algorithm based dynamic reconfiguration. *Energy*. 2022.
- [28] Yousri D, Fathy A, El-saadany EF. Four square sudoku approach for alleviating shading effect on total-cross-tied PV array. *Energy Conversion and Management*. 2022.
- [29] Suresh HN, Rajanna S, Thanikanti SB, Alhelou HH. Hybrid interconnection schemes for output power enhancement of solar photovoltaic array under partial shading conditions. *IET Renewable Power Generation*. 2022; 16(13):2859-80.
- [30] Aljafari B, Satpathy PR, Madeti SR, Vishnuram P, Thanikanti SB. Reliability enhancement of photovoltaic systems under partial shading through a two-step module placement approach. *Energies*. 2022; 15(20):1-27.
- [31] Patro SK, Saini RP. Performance analysis of PV array under partial shading conditions with bypass diode and static array configuration. In *smart energy and advancement in power technologies: select proceedings of ICSEAPT 2021* (pp. 1-8). Singapore: Springer Nature Singapore.
- [32] Saiprakash C, Mohapatra A, Nayak B, Babu TS, Alhelou HH. A novel benzene structured array configuration for harnessing maximum power from PV array under partial shading condition with reduced number of cross ties. *IEEE Access*. 2022; 10:129712-26.
- [33] Yousri D, El-saadany EF, Shaker Y, Babu TS, Zobia AF, Allam D. Mitigating mismatch power loss of series-parallel and total-cross-tied array configurations using novel enhanced heterogeneous hunger games search optimizer. *Energy Reports*. 2022; 8:9805-27.
- [34] Rahiminejad A, Ghafouri M, Atallah R, Lucia W, Debbabi M, Mohammadi A. Resilience enhancement of Islanded microgrid by diversification, reconfiguration, and DER placement/sizing. *International Journal of Electrical Power & Energy Systems*. 2023.
- [35] Muniyandi V, Manimaran S, Balasubramanian AK. Improving the power output of a partially shaded

photovoltaic array through a hybrid magic square configuration with differential evolution-based adaptive P&O MPPT method. *Journal of Solar Energy Engineering*. 2023; 145(5):1-14.

- [36] Thanikanti SB, Kumar P, Devakirubakaran S, Aljafari B, Colak I. A dynamic mismatch loss mitigation algorithm with dual input dual output converter for solar PV systems. *Solar Energy Materials and Solar Cells*. 2023.
- [37] Murtaza AF, Sher HA. A reconfiguration circuit to boost the output power of a partially shaded PV string. *Energies*. 2023; 16(2):1-13.
- [38] Guo Z, Yang B, Chen Y, Li Z, Li Q, Deng J, et al. Modular thermoelectric generation arrays reconfiguration under heterogeneous temperature distribution via improved cooperation search algorithm: modelling, design and HIL validation. *Applied Thermal Engineering*. 2023.
- [39] Dhariwal R, Kumar B. Rearrangement of the PV array to reduce the effect of partial shading using meta-heuristic techniques. In recent advances in power systems: select proceedings of EPREC 2023 (pp. 89-96). Singapore: Springer Nature Singapore.
- [40] Narne DK, Kumar TR, Alla RR. Traditional and hybrid solar photovoltaic array configurations for partial shading conditions: perspectives and challenges. *Bulletin of Electrical Engineering and Informatics*. 2023; 12(2):642-9.



**Isha Kansal** received the B. Tech. degree from Quantum University, Uttarakhand, India, in 2012, and the M. Tech. degree in Engineering Physics from the University School of Basic and Applied Sciences, Guru Gobind Singh Indraprastha University, Dwarka, New Delhi, India, in 2014. She is currently pursuing the Ph.D. degree in Renewable Energy with the Department of Electrical and Electronics Engineering, School of Engineering, University of Petroleum and Energy Studies (UPES), Dehradun, Uttarakhand. She worked as an Assistant Professor with the Department of Electrical and Electronics Engineering, (UPES). She has published quality research articles in international reputed indexed journals. Her fields of research interests include Solar Energy and Applications of different Optimization Techniques used in PV systems. Email: eshaakansal@gmail.com



**Rupendra Kumar Pachauri** received the B.Tech. degree from UP Technical University (formerly), Lucknow, Uttar Pradesh, India, in 2006, the M.Tech. degree from the Electrical Engineering Department, Faculty of Engineering and Technology, Zakir Husain College of Engineering and Technology, Aligarh Muslim University (AMU), Aligarh, India, in 2009, and the Ph.D. degree in renewable energy from G. B. University, India, in 2016. He is currently working as an

Assistant Professor (Selection Grade) with the Department of Electrical and Electronics Engineering, University of Petroleum and Energy Studies (UPES), Dehradun, India. He has published more than 85 research articles in international reputed science citation/Scopus indexed journals along with IEEE/Springer conferences. His fields of research interests include solar energy, fuel cell technology, applications of ICT in PV systems, and smart grid operations. He has performed reviews for high prestigious journals, including IEEE Transactions on Industrial Informatics, IEEE Transactions on Industrial Electronics, Renewable Energy, International Journal of Electrical Power and Energy Systems, and Solar Energy. Email: rpachauri@ddn.upes.ac.in

### Appendix I

S. No.	Abbreviation	Description
1	ACMS	Ancient Chinese Square Matrix
2	BL	Bridge-Link
3	BL-HC	Bridge Link-Honey Comb
4	BL-TCT	Bridge Link- Total Cross Tied
5	CS	Competence Square
6	DAS	Variable Resistive Loads
7	DEAPO	Differential Evolution-Based Adaptive Perturb and Observe
8	DS	Dominance Square
9	ER	Execution Ratio
10	FF	Fill Factor
11	FRA	Flow Regime Algorithm
12	FS	Four Square
13	GA	Genetic Algorithm
14	GMPP	Global Maximum Power Point
15	HC	Honey-Comb
16	I-V	Current-Voltage
17	LMPP	Local Maximum Power Point
18	LS	Latin Square
19	LS-TCT	Latin Square- Total-Cross-Tied
20	LW	Long Wide
21	ML	Mismatch Loss
22	MPP	Multiple Power Points
23	MPPT	Maximum Power Point Tracking
24	MS	Magic Square
25	OE	Odd-Even
26	PE	Power Enhancement
27	PGT	Proposed Game Theory
28	PL	Power Loss
29	PR	Performance Ratio
30	PSCs	Partial Shading Conditions
31	PV	Photovoltaic
32	P-V	Power-Voltage
33	RM	Redesign Method
34	SDK	Su-Do-Ku
35	SMO	Social Mimic Optimization
36	SN	Short Narrow
37	SP	Series-Parallel
38	SPDK	Shape-Do-Ku
39	SP-TCT	Series-Parallel-Total-Cross-Tied
40	STC	Standard Test Condition
41	SW	Short Wide
42	TCT	Total-Cross-Tied